

Assembly and users manual

Pallet racking Omega

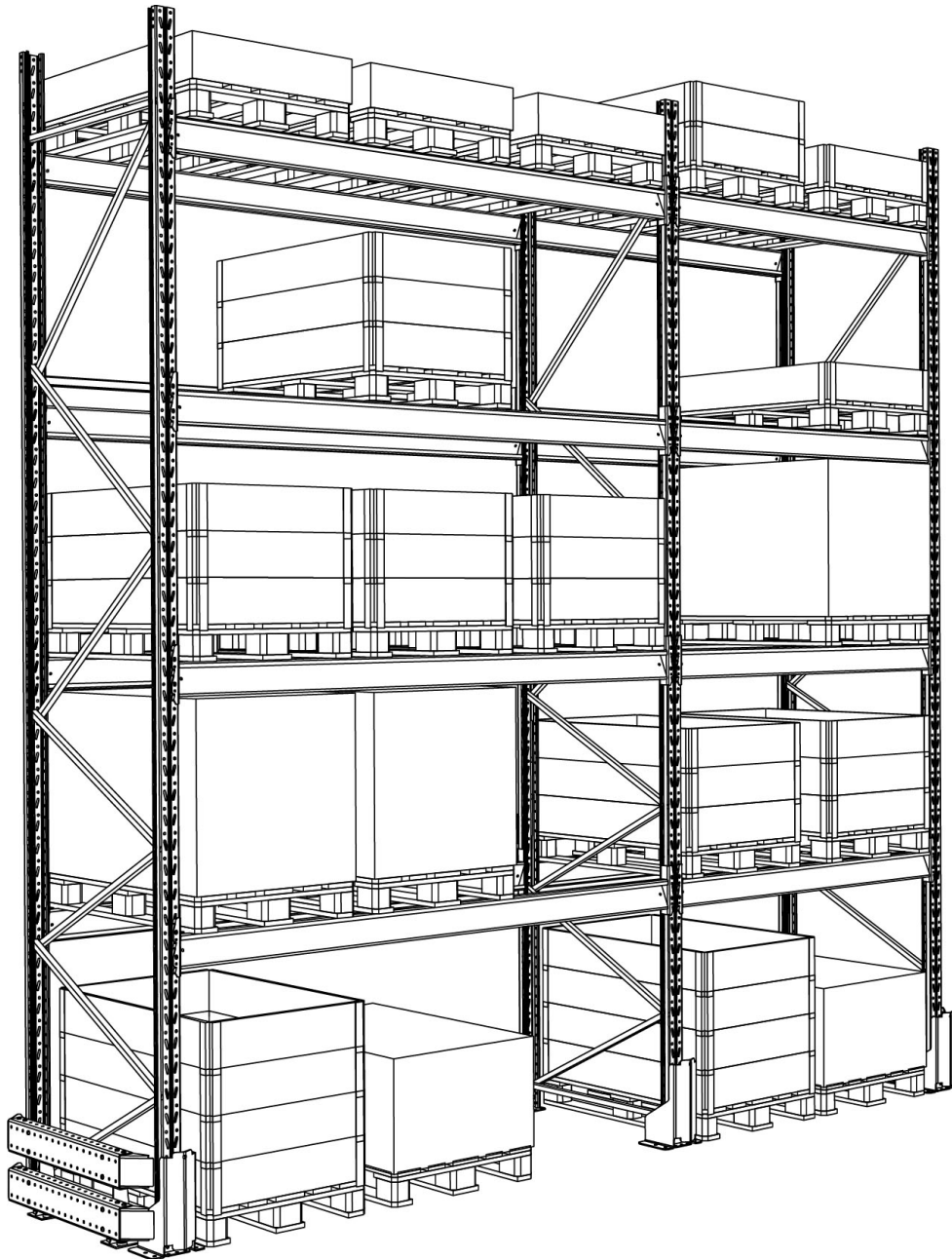

Assembling tools

13 mm Hex socket
16 mm Hex socket
17 mm Hex socket
18 mm Hex socket
19 mm (Upright protector, Frame protector)
6 mm Hex head bit (Upright reinforce, Frame protector)
T25 Torx bit (Vertical drive through protector)
T30 Torx bit (Pallet support bar)
10 mm Concrete drill bit
12 mm Concrete drill bit (Upright protector, Frame protector)
Driver/Impact wrench (with adjustable torque)
Level alt. Laserliner
Rotary Hammer alt. Hammer-drill
Hammer

Concrete floor

The concrete grade shall be minimum C 25/30

Construction joints must not pass through the rack, because a movement in the joint can cause unpredictable forces in the rack. Construction joints shall be placed between the racks.

Purchaser/User is responsible that the floor is designed for the actual loads.

EAB can by request provide information about floor loads from the rack.

Maximum height tolerances

Measure	Measure length	Tolerance
Flatness	0,25 m	$\pm 1,2$ mm
Flatness	2,0 m	± 5 mm
Lutning		1/600

All points, regarding both flatness and slope, shall be within ± 20 mm of the horizontal datum.

If the floor is not made of concrete, please contact EAB

Tightening Torque

Screw M10 8.8 Max. tightening torque 47 Nm

Taptite M6 Max. tightening torque 5 Nm

Taptite M8 Max. tightening torque 15 Nm

Screw B31K 5,5x20 Max. tightening torque 5 Nm

Skruvförbanden ska dras till god anliggning.

Lock nut M10 class 8

Tighten screw joints for good contact.

Max. tightening torque must not be exceeded.

For assembly of bracing in frame

Screw M8x75/12 Max. tightening torque 8-12 Nm

Lock nut M8 class 8

Use driver with adjustable torque

Calibrate the driver with a torque wrench

Expansion anchors

M10x90 Hilti HST

Drill hole $\varnothing 10$ - 80 mm

Min. mounting depth 69 mm

Max. thickness fastened 10 mm

M12x100 Hilti HSA

Drill hole $\varnothing 12$ - 95 mm

Min. mounting depth 65 mm

Max. thickness fastened 20 mm

See Hiltis instructions on the package.

If the distance between the anchor and the concrete edge is less than 9x anchor diameter, please contact EAB.

ASSEMBLING OF FRAMES

1. Fasten sleeve to fotplate

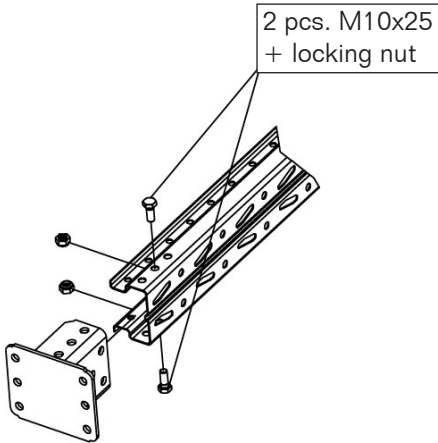

2. Place braces according to frame views page 5

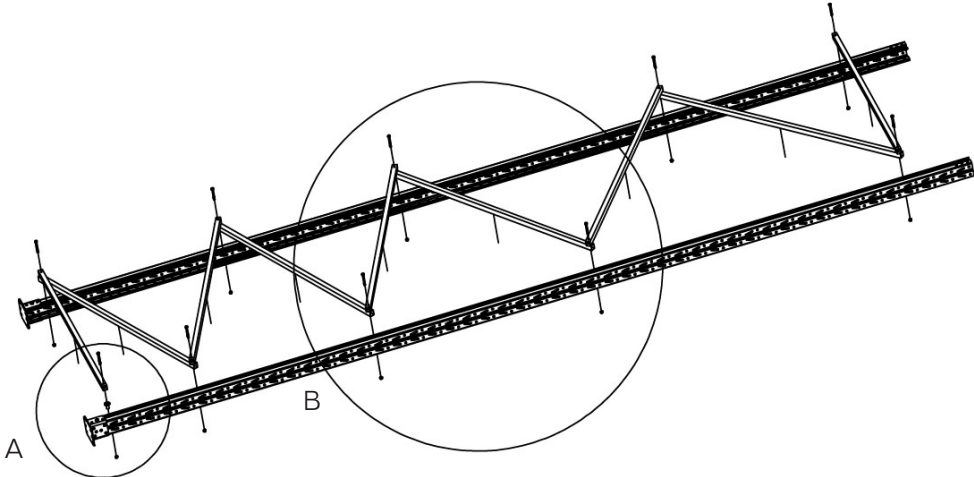

3. Place a spacer at free side of horizontal brace

4. Fasten all braces
Tightening moment Max 8-12 Nm

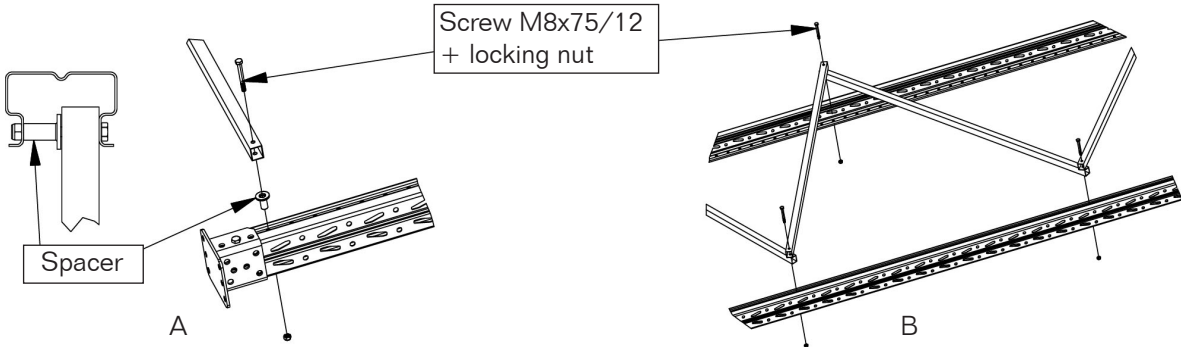

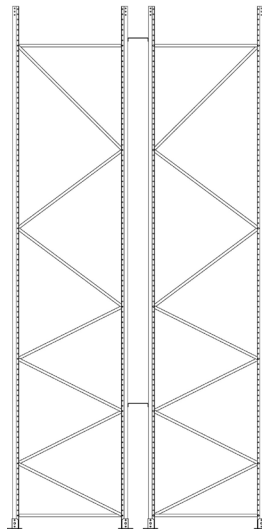
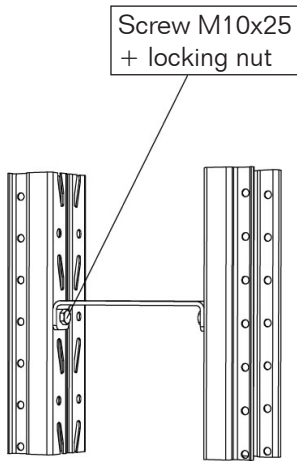

Frame setup

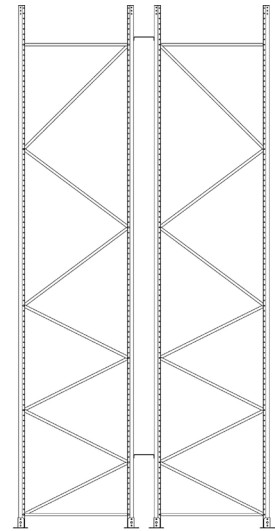

Alternativ frame setup

5. Level the floor to find the highest spot. The spot will determine by how much the rack needs to be leveled. Raise the first section and fit two safety pins per horizontal beam.

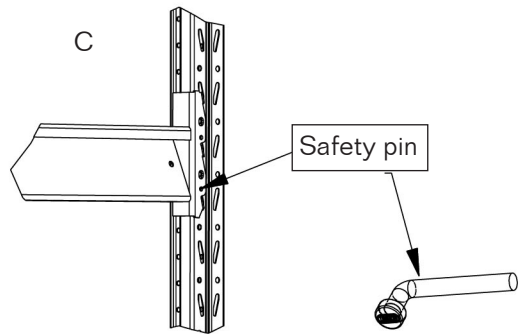
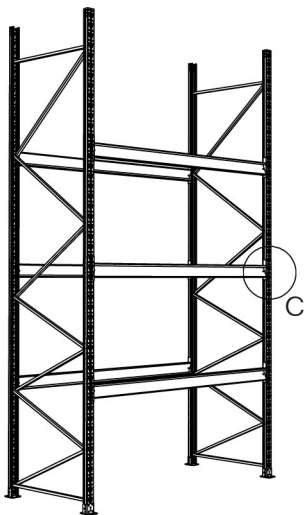

6. If the floor is uneven, the footplate shall be adjusted with leveling plates to attain a horizontal level.
 Max leveling: 25mm
 Footplate anchors with 2 pcs expansion anchors M10x90.
 If leveling exceeds 5 mm then use expansion anchors M10x110.

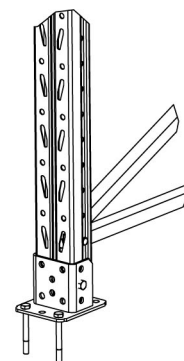
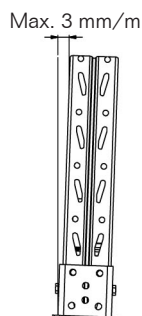
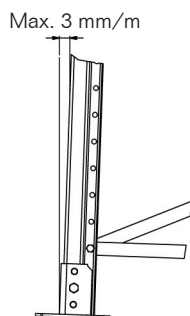

Dimensions - 800 mm frames

Brace type	Rise per brace	Length of brace (90 upright)	Length of brace (110 upright)
0	0	747	733
1	500	906	895
2	750	1071	1061
3	1000	1265	1257

Dimensions - 900 mm frames

Brace type	Rise per brace	Length of brace (90 upright)	Length of brace (110 upright)
0	0	847	833
1	500	989	977
2	750	1142	1131
3	1000	1325	1316

Dimensions - 1100 mm frames

Brace type	Rise per brace	Length of brace (90 upright)	Length of brace (110 upright)
0	0	1047	1033
1	500	1164	1152
2	750	1296	1284
3	1000	1459	1449

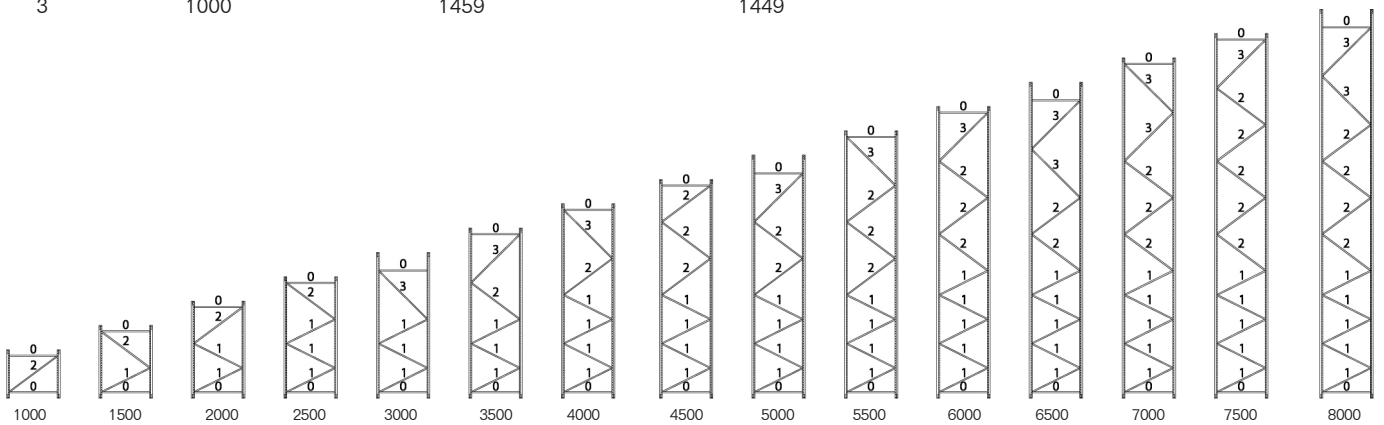

Dimensions - 500 mm frames

Brace type	Rise per brace	Length of brace (90 upright)	Length of brace (110 upright)
0	0	447	433
1	500	685	676
2	750	893	887

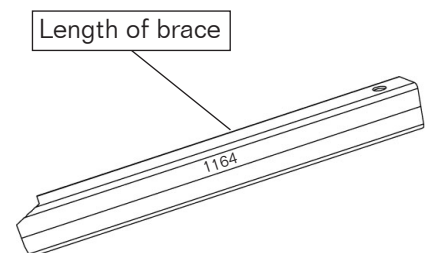
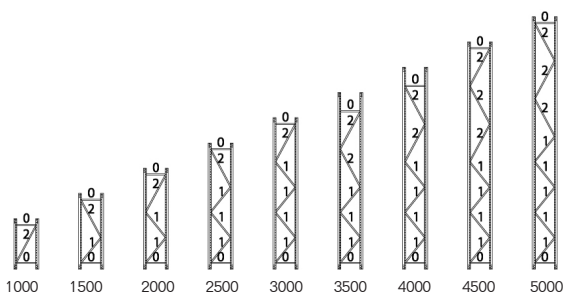

UPRIGHT PROTECTOR/REINFORCE

UPRIGHT PROTECTOR HEIGHT 400 MM

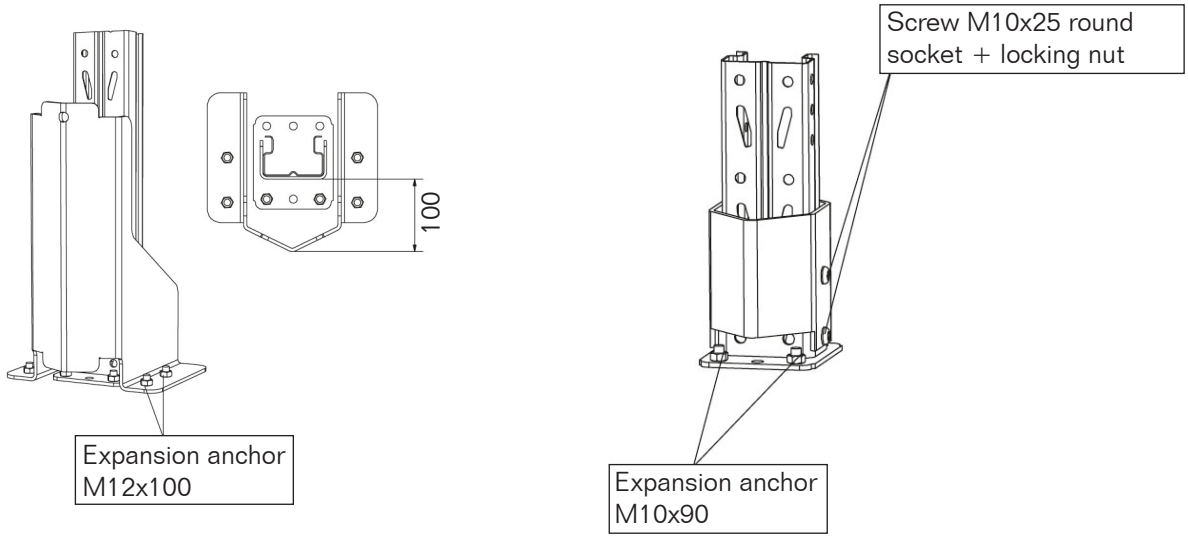

UPRIGHT REINFORCEMENT HIGH

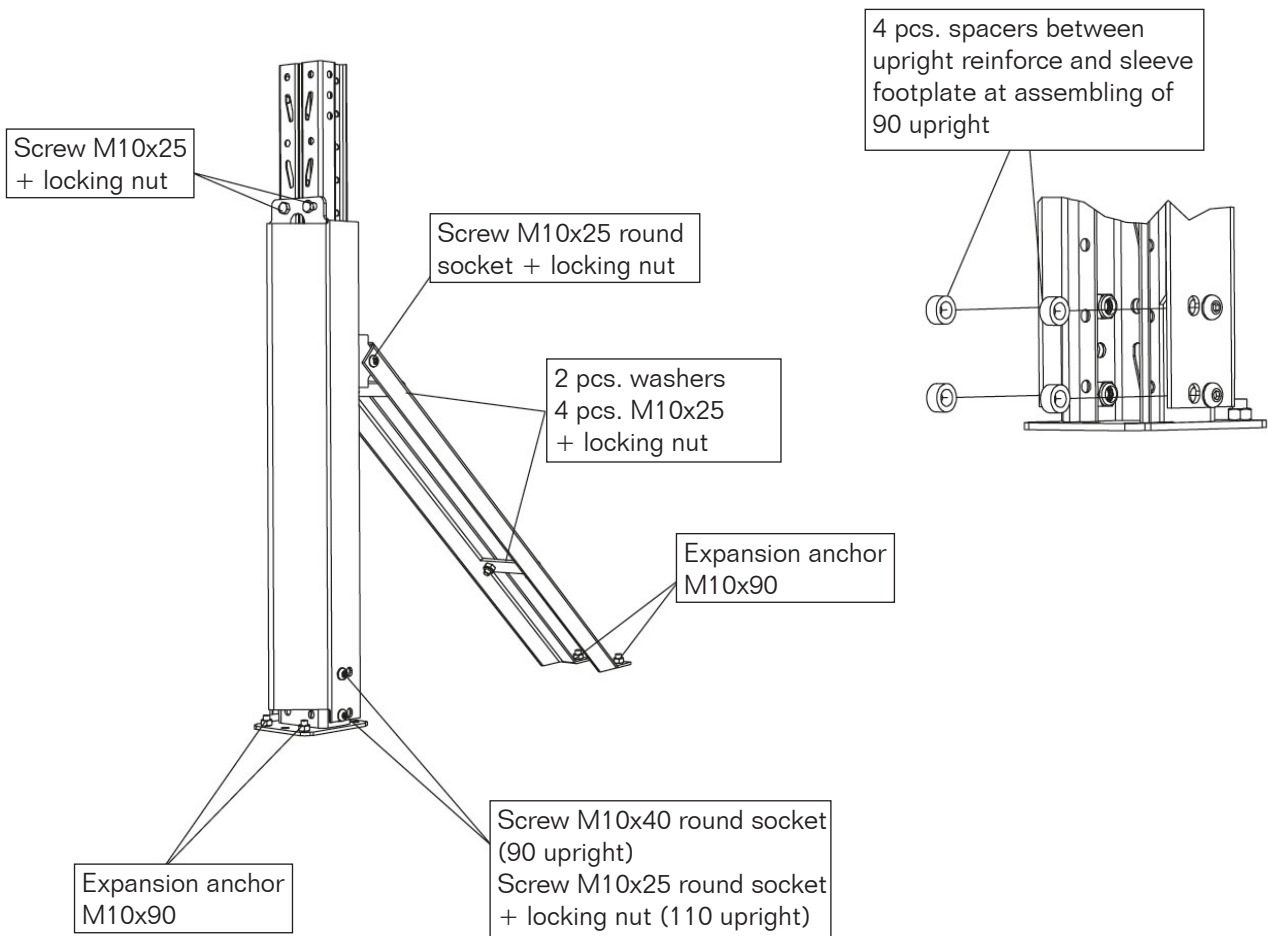

FRAME PROTECTOR HEIGHT 400 MM

END PLATE

4 pcs. screw M10x25 round socket + locking nut

U-PROFILE PROTECTOR + FOOT

2 pcs. screw M10x25 round socket + locking nut

FOOT

2 pcs. expansion anchor M12x100
+ washer 12,5x35x,3
+ pu-spring 40x13x10
+ locking nut

1 pcs. expansion anchor M12x100

Max c/c 1100 mm

FRAME PROTECTOR HEIGHT 180 MM

END PLATE

4 pcs. screw M10x25 round socket + locking nut

SPLICE

8 pcs. screw M10x25 round socket + locking nut

FOOT

2 pcs. screw M10x25 round socket + locking nut

Splicing plate

FOOT

3 pcs. expansion anchor M12x100

MOUNTING FEET WITH PU-SPRING IN CONCRETE FLOOR

For mounting frameprotection on asphalt, please see page 14.

The frame protector fulfill the requirements according to SS-EN 15512, even during assembly without pu-spring. We recommend that the pu-springs are always installed, since it increases the frame protectors capacity against repeatedly collisions.

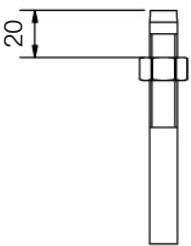

1. Screwing down a nut 20 mm on a M12 expansion anchor.

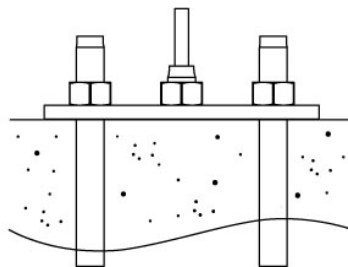

2. Hammer down and tighten the expansion anchor.

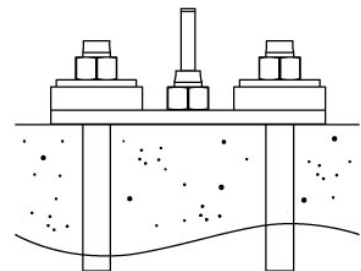

3. Unscrew the nut and provide 2 pcs expansion anchor with pu-spring, washer and locking nut. Tighten the locking nut to good contact to the washer.

ACCESSORIES

BRACING FOR BEAM 3600 MM

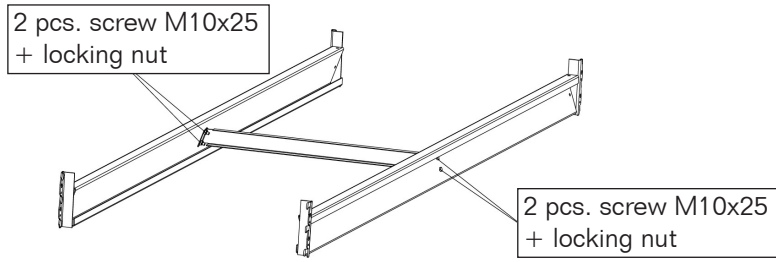

HORIZONTALLY DRIVE THROUGH PROTECTOR

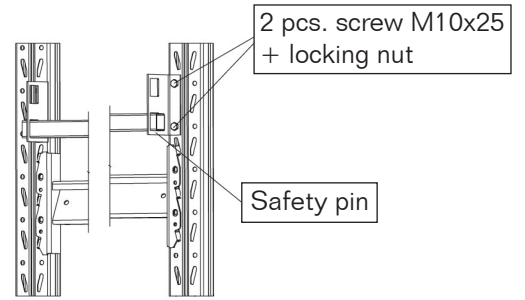

Beam L=3600mm with bracing gets increased capacity from 4x800 kg to 4x1000 kg.

HALF PALLET SUPPORT

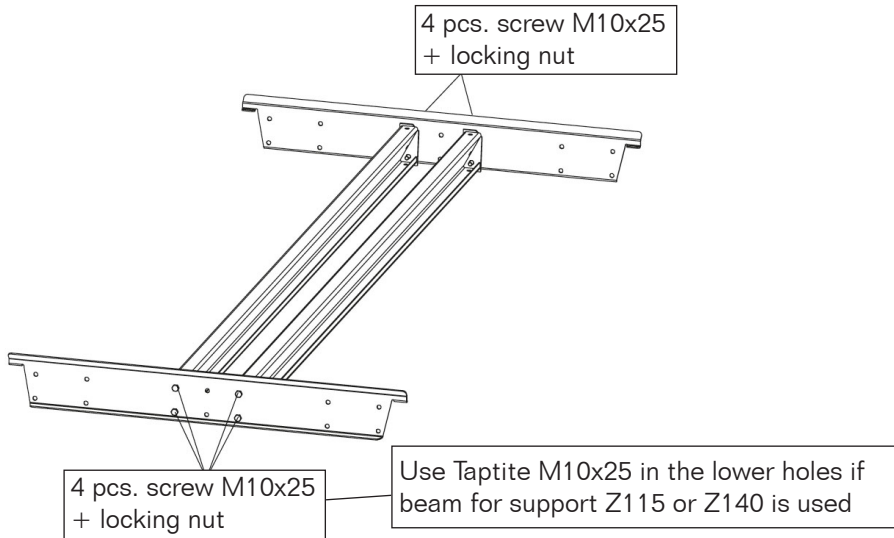

PALLET SUPPORT BAR

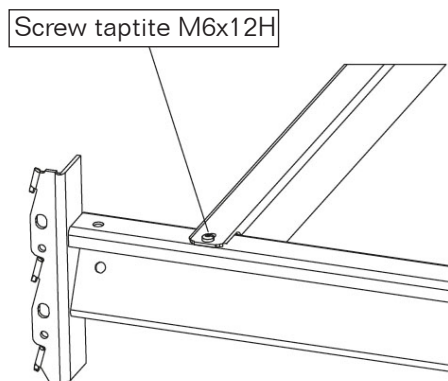

JOINT SLEEVE

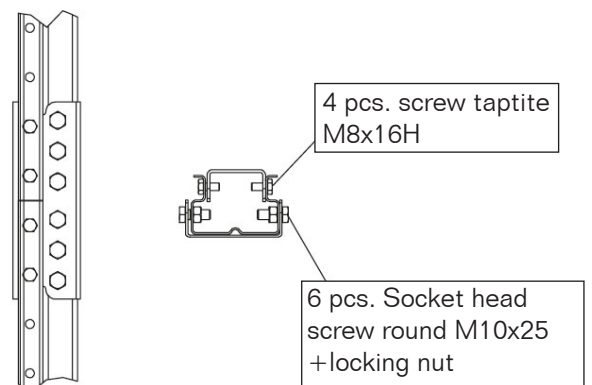

VERTICAL DRIVE THROUGH PROTECTOR

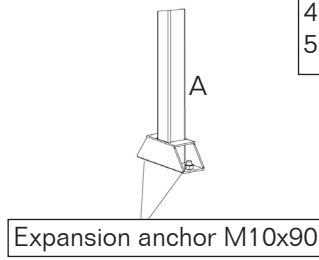
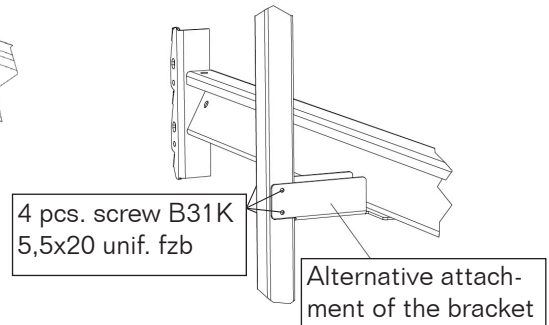
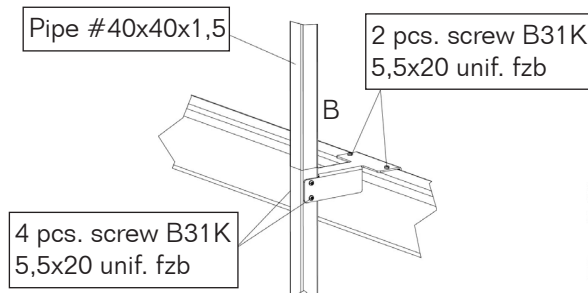
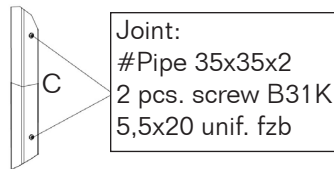
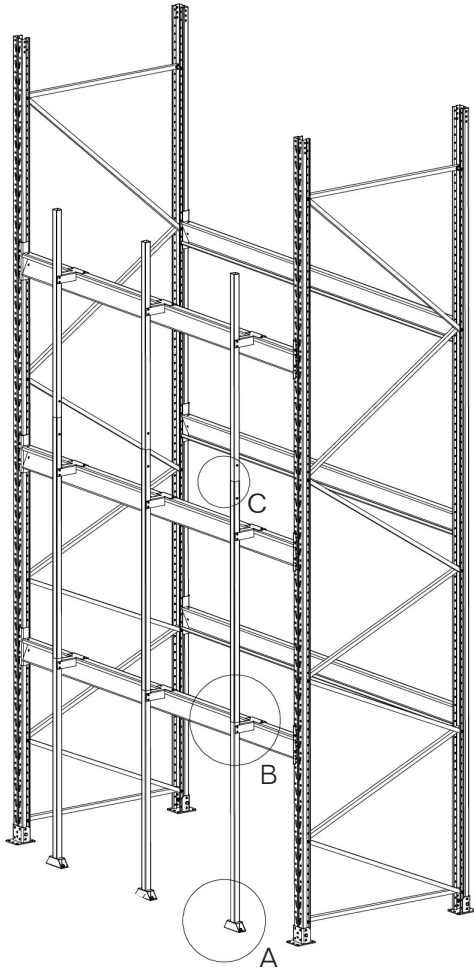

PALLET SUPPORT B=100

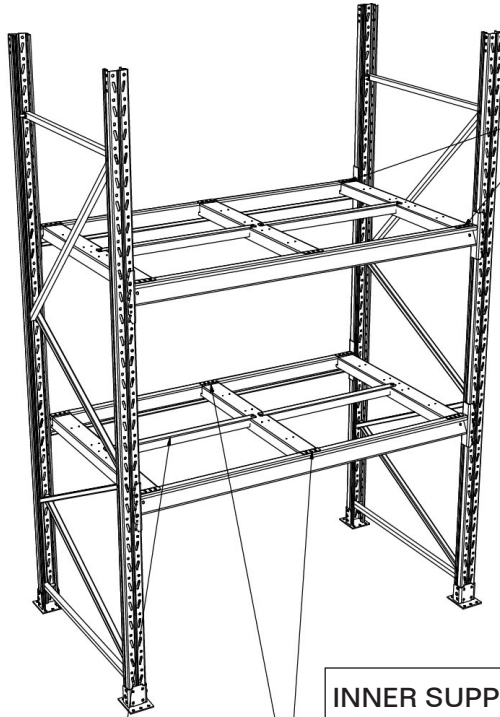

OUTER PALLET SUPPORT B=100
If the distance between pallet support and upright > 50 mmbolt these with 1+1 screw taptite M16x12H
Pre-drill Ø5,5 mm in beam

All pallet support
U42x48 bolts with 2 pcs
screw taptite M6x12H.

INNER SUPPORT B=100
Fix to beam with 1+1 Screw
Taptite M6x12H / support.
Pre-drill Ø5,5 mm in beam.

OUTER SUPPORT B=100
If the distance between support and upright >50mm fix it with 1+1 screw taptite M6x12H.
Pre-drill Ø5,5 mm in beam.

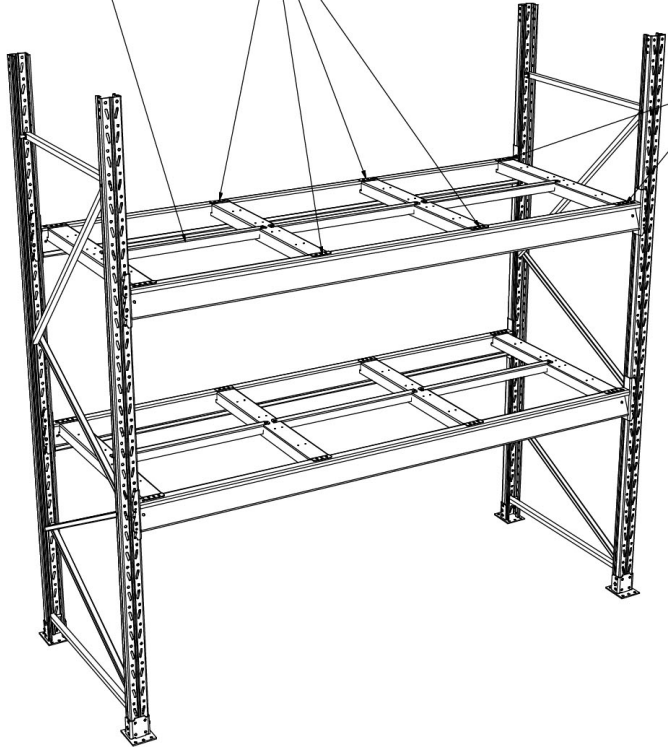

MESH PANEL

PLACING OF NET SUPPORTS

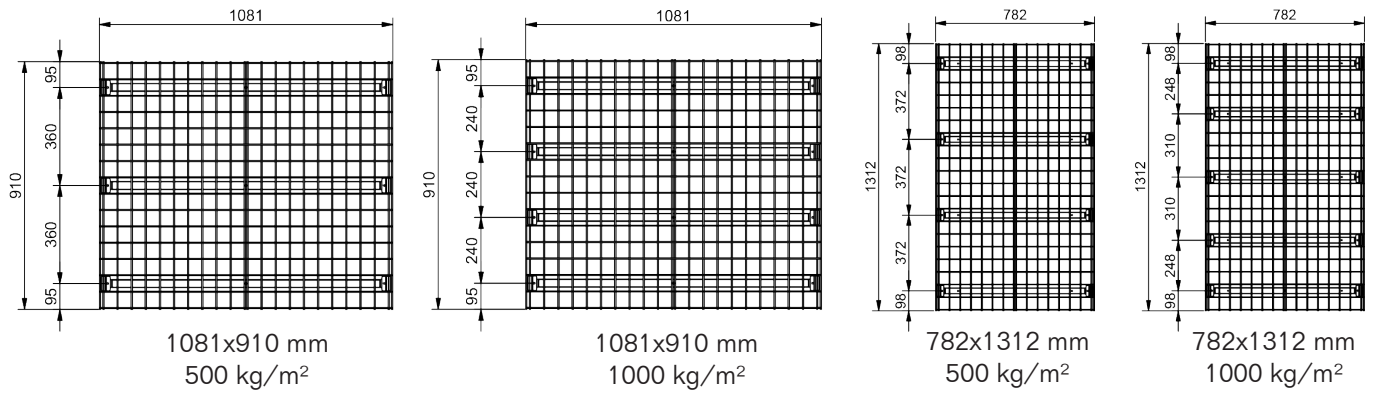

ASSEMBLY JIG

NET SUPPORT

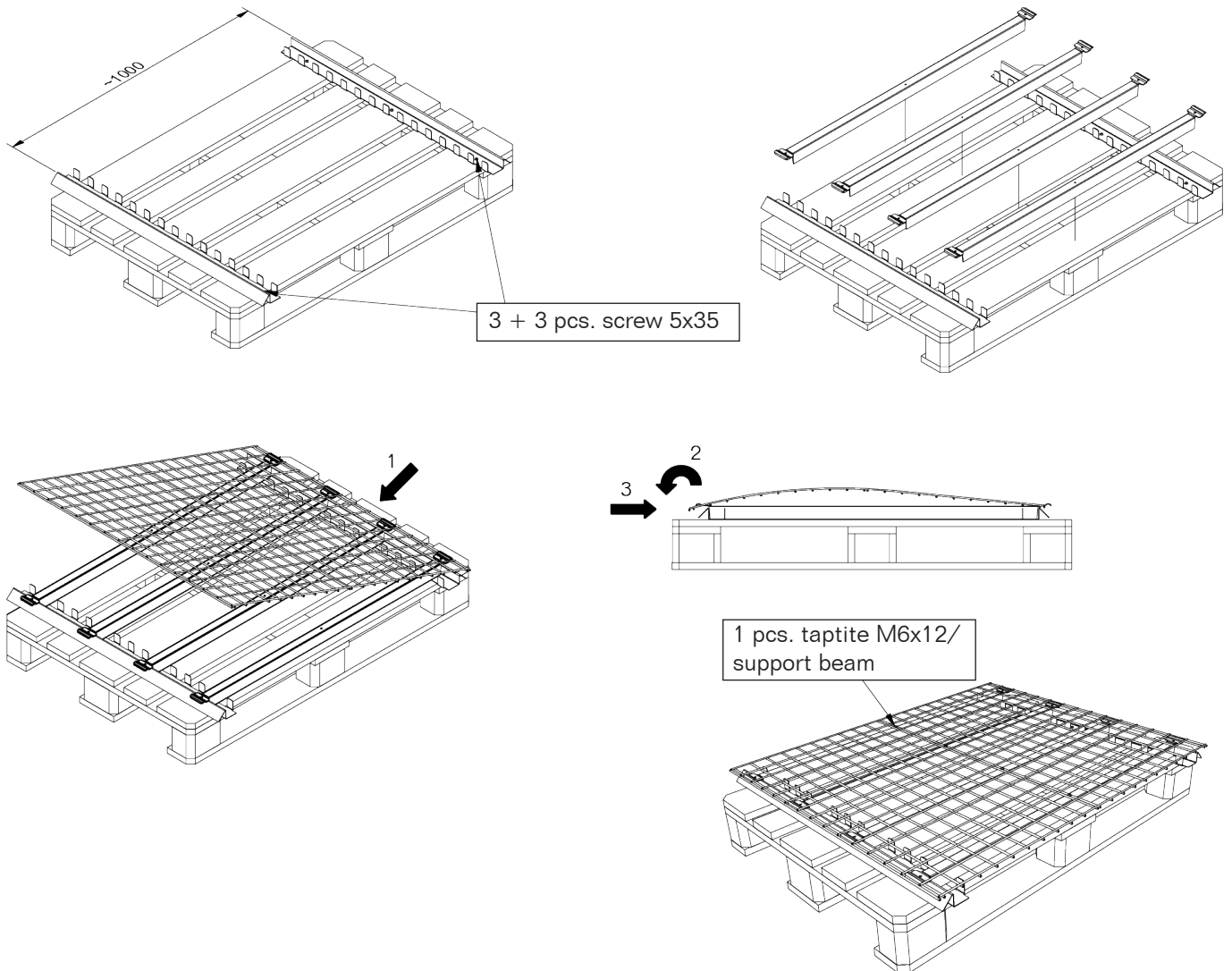

MESH PANEL BOLTS TO BEAM

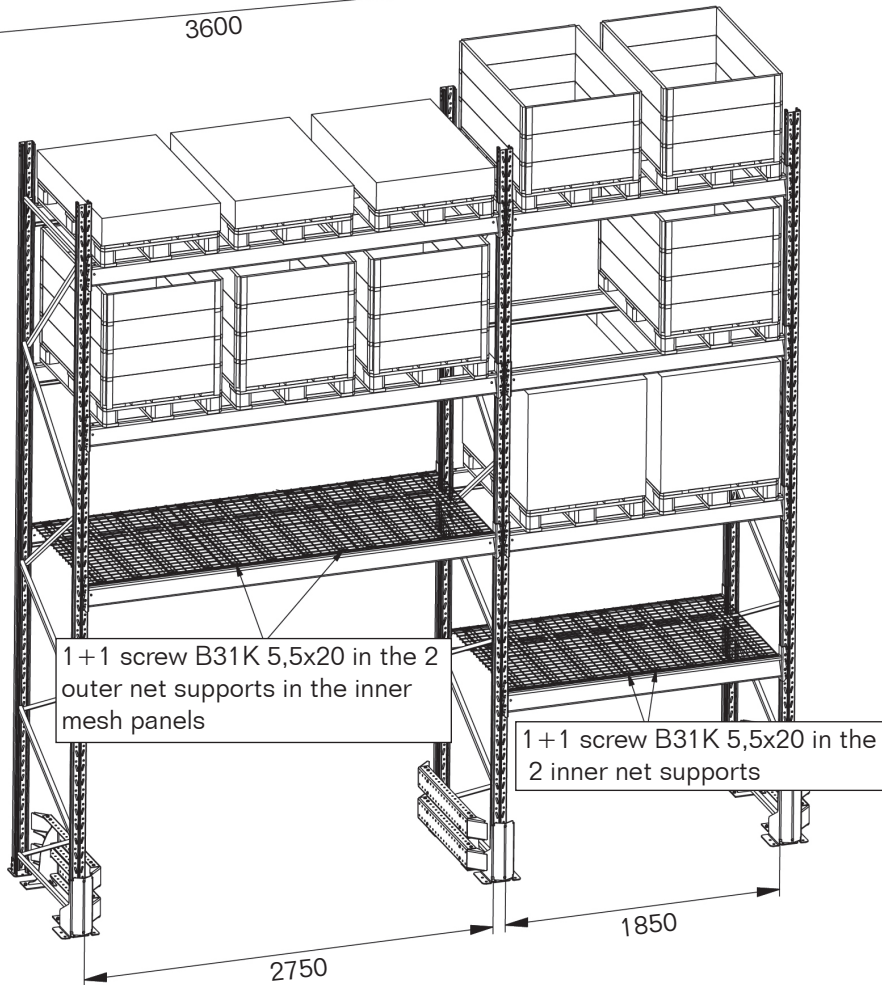
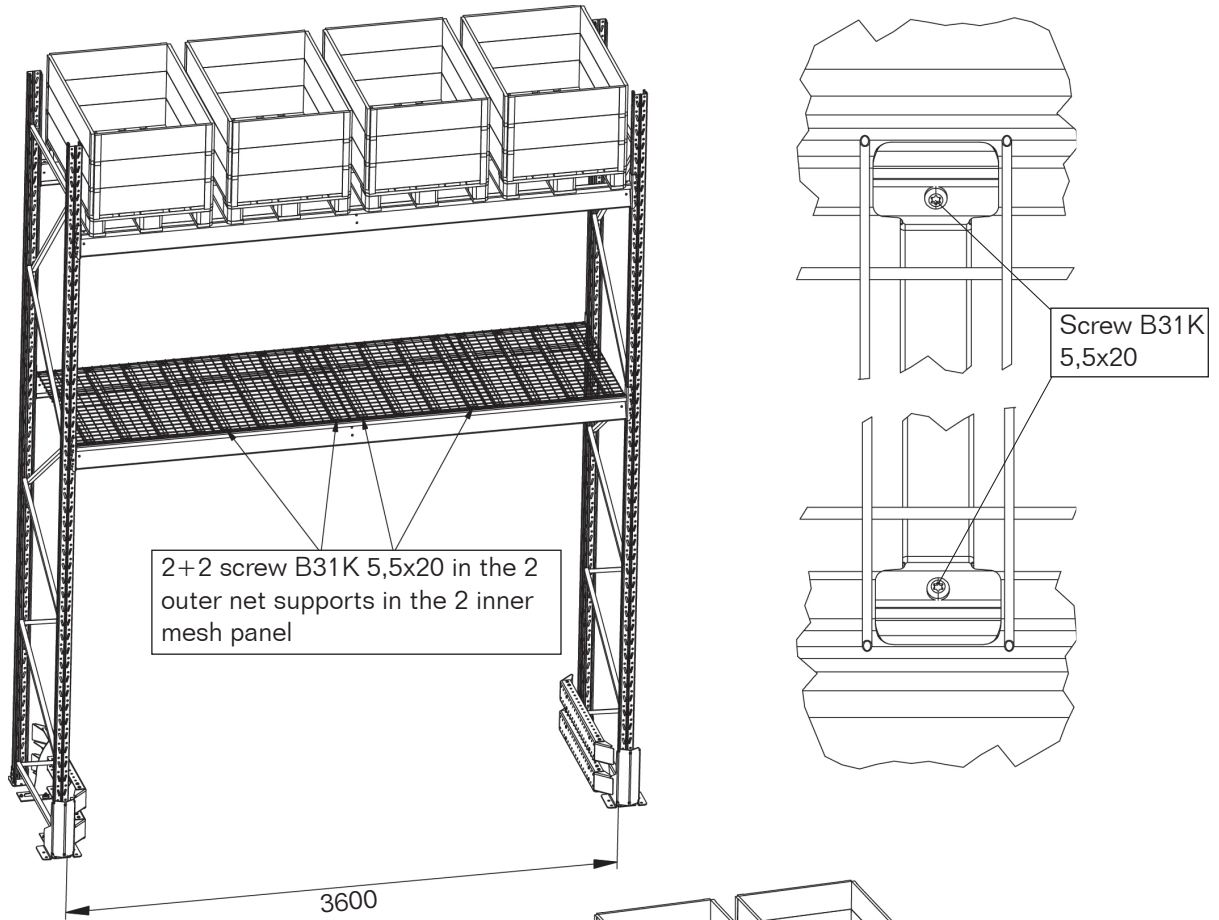

ASPHALT PLATE

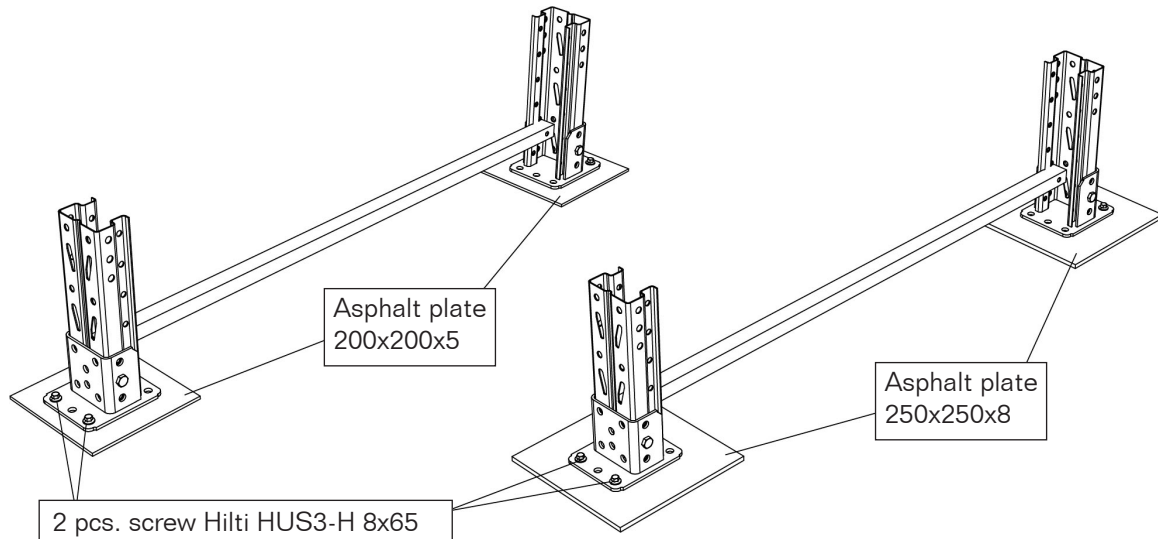

ASSEMBLY OF PALLET RACKING ON ASPHALT

Leveling plate

Max 10 mm leveling

Placed between sleeve footplate and Asphalt plate.

Concrete bolt in asphalt

+ asphalt glue "Häftprimer EP"

Before use, read the operating instructions and safety instructions on the packaging for Häftprimer EP. For complete product data, see www.hagmans.se.

Drill hole shall be filled with asphalt glue Häftprimer EP before bolt is fitted.

Hilti HUS3-H 8x65

Drill hole $\varnothing 8 - 70$ mm

Min. mounting depth 50 mm

Max. thickness fastened 15 mm

Tighten carefully.

Allowed loads

Asphalt plate 200x200x5:

Max 3 ton/foot

Max. section load 6 ton/section

Asphalt plate 250x250x8

Max 5 ton /foot

Max section load 10 ton /section

Max loads apply provided that asphalt and bearings are of such good quality that the permissible surface pressure on asphalt for long-term loads is min 0.8 Mpa. For more information on loads see Load plate Omega 90-1 / 90-2 asphalt.

For higher foot loads than allowed or for asphalt of worse quality require larger and thicker Asphalt plates, which is dimensioned by project. The client / user shall approve calculated surface pressure on asphalt.

ASSEMBLY OF FRAME PROTECTION ON ASPHALT

Mounting

1. Mount the frame protection (see Assembly instruction Upright and frame protector).
2. Screw the asphalt plates onto the feet with 3 M12x16 + Washer 13x24x2 / Foot.
3. Place the frame protection in place and drill $\varnothing 10$ holes in the asphalt through the plate's $\varnothing 13$ hole.
4. After drilling, remove and clean protection and asphalt.
5. Return the frame protection, fill the drill holes and the 6 oval holes with asphalt glue.
6. Tighten the frame protection with Hilti HUS3-H 10x70 (YD 12.5)
7. Pour glue into rounds in the oval holes until the glue runs out to the edge of the plate.

Concrete bolt in asphalt + asphalt glue "Häftprimer EP"

Before Use, Read the Operating Instructions and Safety Instructions on the Packaging for Häftprimer EP.

For complete product data, see www.hagmans.se

Drill hole shall be filled with asphalt glue Häftprimer EP before bolt is fitted.

Hilti HUS3-H 10x70

Drill holes $\varnothing 10$ -75 mm

Min mounting depth 55 mm

Max thickness fastened 15 mm

Tighten carefully.

NOTE! When installing frame protection for asphalt, the requirement for energy absorption is not met according to SS-EN 15512.

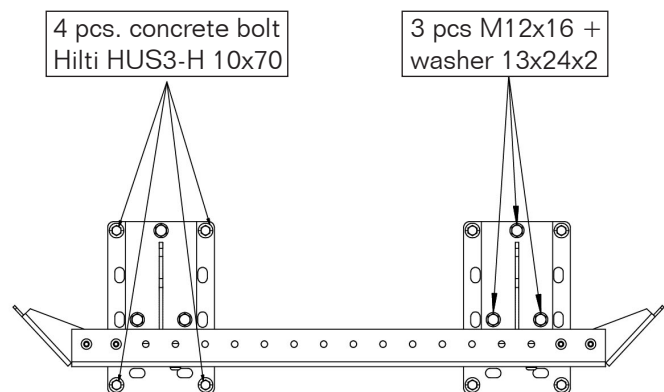
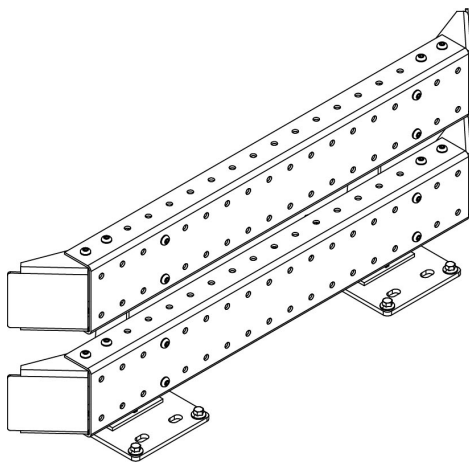

SAFETY IN WAREHOUSES

EAB's pallet racking employ a proven design, with maximum emphasis on safety and performance. The Pallet racking fulfil all safety requirements in the European Standards, SS-EN 15512, SS-EN 15620, SS-EN 15629 and SS-EN 15635 which includes rules for static design, testing, assembly and marking.

Assembly/modification

To ensure safety, it is important that pallet racking are always assembled in accordance with the instructions given here. The diagram on the outside back cover shows how the frames are affected by changes in the positions of the beam levels. The height from the floor to the first beam level affects the load-carrying capacity of the frame, as does the distance between levels.

Marking

The uprights are stamped with their maximum load-carrying capacity per section, while the horizontal beams are stamped with their maximum load-carrying capacity per level. The rating plates supplied with the frames must be fitted in clearly visible positions, and it is the responsibility of management to see that loading information given on them is complied with.

Maintenance

Any damage caused by trucks etc. colliding with the racking frames must be rectified immediately, as such damage can often affect the load-carrying capacity of the frames. An upright member that has been hit is always a safety risk, and must be replaced.

Accessories

An effective way of improving safety is to complement the frames with protectors, pallet stop, half-pallet support bars etc.

Inspection

Erections inspection

Before starting to use the pallet racking, it must be inspected in accordance with these instructions and in any special erection drawings.

Regular inspection

Pallet racking must be regularly inspected in respect of locking devices, bracing, damage by vehicles etc. and anything else that could affect their strength.

Periodic inspection

Pallet racking must be inspected at least every twelve months to ensure that they continue to comply with these instructions and with any special erection drawings.

Re-inspection

Must always be performed if the positions of the horizontal pallet support beams are moved or if the frames are altered in any other way.

The purchaser or user is responsible for ensuring that the above inspections are performed.



SE- 333 33 SMÅLANDSSTENAR
TEL +46 371-340 00 www.eab.se